

CS30 Owner's Manual

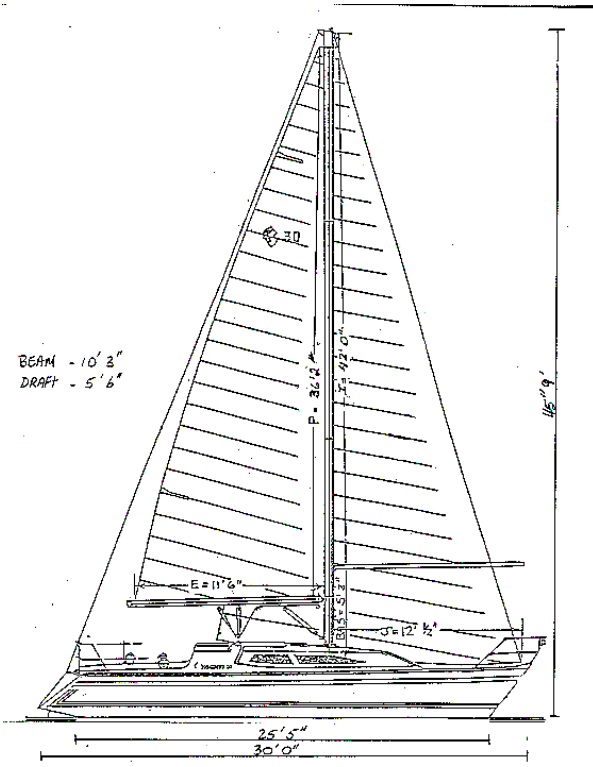

TABLE OF CONTENTS

1. INTRODUCTION	5
2. SPECIFICATIONS	6
2.1. GENERAL DIMENSIONS	6
2.2. TANKAGE	6
2.3. SAIL PLAN	6
3. SAFETY EQUIPMENT	7
3.1. FIRE EXTINGUISHER	7
3.2. LIFE JACKETS	7
3.3. LIFE BUOY	7
3.4. SAFETY HARNESSSES	7
3.5. LIFELINES	7
3.6. DINGHY AND LIFE RAFT	8
3.7. FLASHLIGHTS	8
3.8. SAFETY FLARES	8
3.9. FOG SIGNALS AND RADAR REFLECTORS	8
4. CONTROLS	9
4.1. LIGHTING	9
4.2. A/C POWER	9
4.3. BATTERY	9
4.4. GALLEY	9
4.5. ENGINE	10
5. LAUNCHING PROCEDURE	11
5.1. PRE-LAUNCH CHECKLIST	11
5.2. IN-WATER CHECKLIST	11
5.3. STEPPING THE MAST	12
6. WINTER LAY-UP AND STORAGE	14
6.1. UN-STEPPING THE MAST	14
6.2. HAULING-OUT AND SLING LOCATION	15
6.3. CRADLE SUPPORT	16
6.4. WINTERIZING PROCEDURE	18
6.5. HEAD AND HOLDING TANK	19
6.6. FRESH WATER SYSTEM	19
6.7. AUXILIARY PUMPS	21
6.8. BALL VALVES	21
6.9. BATTERIES	21
6.10. UPHOLSTERY	21
6.11. DECK HARDWARE	21
6.12. LOCKERS AND ENCLOSURES	21
7. MAINTENANCE	22
7.1. GELCOAT SURFACES	22
7.2. GELCOAT REPAIRS	22
7.2.1. <i>Application of Gelcoat</i>	22
7.2.2. <i>Surface Finishing</i>	23
7.3. CARE OF HATCHES AND PORTS	23

CS30 Owner's Manual

7.4.	TEAK.....	24
7.5.	BOTTOM OF THE HULL.....	24
7.6.	LIFELINES PULPITS AND STANCHIONS	24
7.7.	WINCHES AND BLOCKS	24
7.8.	STANDING RIGGING	25
7.9.	RUNNING RIGGING.....	25
7.10.	ENGINE AND DRIVETRAIN.....	25
7.11.	ELECTRICAL SYSTEM MAINTENANCE	26
7.12.	UPHOLSTERY	26
8.	CONSTRUCTION.....	27
8.1.	HULL.....	27
8.2.	HULL & DECK CONNECTION	27
8.3.	DECK	27
8.4.	STEERING AND RUDDER.....	27
8.5.	BALLAST	27
8.6.	INTERIOR CONSTRUCTION.....	28
8.6.1.	<i>Removing the cabinets in a CS30 (Port Side).....</i>	<i>28</i>
8.6.2.	<i>Removing the cabinets in a CS30 (Starboard Side).....</i>	<i>29</i>
8.6.3.	<i>Opening Ports.....</i>	<i>29</i>
9.	RIGGING	30
9.1.	GENERAL	30
9.2.	RIG TUNING.....	33
10.	POWER PLANT AND TRANSMISSION.....	35
10.1.	ENGINE.....	35
10.2.	FUEL SYSTEM	35
10.3.	PROPELLER SHAFT ALIGNMENT	36
10.4.	STUFFING BOX.....	37
10.5.	PROPELLER ALIGNMENT	38
11.	ELECTRICAL	39
11.1.	BATTERIES.....	39
11.2.	ALTERNATOR	39
11.3.	ELECTRONIC EQUIPMENT.....	39
12.	INSTALLATION OF FITTINGS.....	41
12.1.	DECK FITTINGS	41
12.2.	THROUGH HULL FITTINGS	41
13.	TABLES.....	42
13.1.	LUBRICANTS, FILTERS AND CAPACITIES.....	42
13.2.	ELECTRICAL LIGHTS	43
13.3.	STAINLESS STEEL COMPONENTS	43
13.4.	STANDING RIGGING	44
13.5.	STANDARD RUNNING RIGGING	45
13.6.	BLOCK SPECIFICATIONS.....	46

LIST OF ILLUSTRATIONS

Figure 1 - Propane System with Solenoid Actuated Valve	10
Figure 2 - Mast Sling Location.....	16
Figure 3 - Haulout Sling Location	17
Figure 4 - Toilet Plumbing System.....	19
Figure 5 - General Plumbing Schematic.....	20
Figure 6 - Typical Keel Attachment.....	28
Figure 7 - Mast & Rigging Layout	31
Figure 8 - Spreader Arrangement.....	32
Figure 9 - Chainplate & Shroud Detail	33
Figure 10 - Fuel Tank Installation	36
Figure 11 - Propeller Shaft & Stuffing Box.....	37
Figure 12 - Standard 2-Blade Propeller	38
Figure 13 - Mast Lighting System	40
Figure 14 - VHF Radio Connections.....	40
Figure 15 - Through Hull Fitting.....	41

LIST OF TABLES

Table 1 - General Dimensions	6
Table 2 - Tankage	6
Table 3 - Sail Plan Dimensions.....	6
Table 4 - Lubricants, Filters and Capacities	42
Table 5 - Electrical Lights	43
Table 6 - Stainless Steel Components	43
Table 7 - Standing Rigging Specifications	44
Table 8 - Running Rigging Specifications.....	45
Table 9 - Block Specifications	46

Date	Version Number	Description
1987		Original manual published by CS Yachts
February 2000	2K0205	Original manual OCR scanned and edited but without most diagrams. Interior construction notes added to Section 8.
April 2000	2K0422	Illustrations and some tables added

CS30 Owner's Manual

1. Introduction

This manual has been provided to help you to familiarize yourself with the operation and maintenance of your yacht. It is important that you read this manual as well as the additional component manuals provided by the manufacturers and included in this package.

At CS Yachts, we are continually improving and upgrading our yachts to serve you, the buyer, better. For this reason you may find your boat equipped with equipment that is different from that shown in your manual. We will endeavor to keep you, through your dealer, informed about any changes or improvements made to your specific boat. .

If any questions remain or if you have a suggestion to make on how we can improve our boats please feel free to contact your dealer and/or the factory.

Remember, upon taking delivery of your yacht, fill out your warranty or change of ownership card and return it to the factory after you have read and understood your CS warranty.

CS30 Owner's Manual

2. Specifications

2.1. General Dimensions

Length-over-all (LOA)	30 ft
Length-at-waterline (LWL)	25 ft 5 in
Beam	10 ft 3 in
Draft - Deep Keel (D)	5 ft 6 in
Draft - Shoal Keel (S)	4 ft 3 in
Draft - Wing Keel (W)	4 ft 6 in
Sail Area: 100% fore triangle	589 sq ft
Masthead to Waterline	45 ft 9 in
Pulpit to Waterline	5 ft
Battery Capacity	112 amp hrs
Battery Capacity - 2 battery option	224 amp hrs
Engine - Volvo Penta Diesel	18 hp

Table 1 - General Dimensions

2.2. Tankage

Fresh Water	30 US gallons
Fuel	18 US gallons
Waste Holding	25 US gallons
Ice Box	6 cu ft
Propane	11 lbs

Table 2 - Tankage

2.3. Sail Plan

I	42 ft.
J	12 ft. 1/2 in.
P	36 ft. 6 in.
SPL	12 ft. 1/2 in.
Main Sail	210 sq. ft.
No. 1 Genoa	380 sq. ft.
Total Sail Area: 100% fore triangle	460 sq. ft.
Total Sail Area: 150% fore triangle	590 sq. ft.

Table 3 - Sail Plan Dimensions

3. Safety Equipment

The safety of the crew, the yacht, and other boaters should be the primary concern of every sailor. Towards this end, certain pieces of equipment should be carried on board your yacht. Although the laws concerning what must be carried on board legally, vary from country to country, the items listed below are generally considered to be the absolute minimum.

3.1. Fire Extinguisher

At least two Class B or C, 2 1/2 pound fire extinguishers should be carried aboard every yacht and it is often desirable to carry 2 or 3 extinguishers mounted in various easily accessible locations. The recent Halon extinguishers have proven to be the best on all types of fires and should be seriously considered for larger yachts. **[Ed. note: Halon is now illegal]**

3.2. Life Jackets

At least one life Jacket or personal floatation device (PFD) of proper size should be carried for each person aboard. Only DOT (Canada) or Coast Guard (USA) approved life preservers should be used as these have been tested and found to be safe.

3.3. Life buoy

Yachts should carry a 24-in. round life buoy, not the horseshoe/pony ring type of life buoy, which is not DOT or Coast Guard approved. Both can easily be stored in a bracket on the stern rail or next to the helmsman. The life buoy should have a signal light, such as a gravity-activated strobe, attached to it along with a 50-ft. line. The other end of this line should be attached to a man overboard pole which is stored on the yacht's lifeline and goes overboard after the life buoy.

3.4. Safety Harnesses

As with life jackets a safety harness should be worn by anyone on deck at night and during heavy weather sailing. These allow the wearer to attach himself to some permanent fixture on or above deck and should be strong enough to take the full load of the wearer falling several feet.

3.5. Lifelines

Lifelines should be inspected regularly to verify their integrity. Carefully check that the swage fittings are not pulling and that the lock nuts on the turnbuckles and snap shackles are tight.

CS30 Owner's Manual

3.6. Dinghy and Life Raft

For offshore racing or cruising, an inflatable dinghy or life raft must be carried and be big enough to accommodate every member of the crew safely. Inflatable-dinghies should be checked once every 2 years to ascertain if they are still in working order.

3.7. Flashlights

Every yacht should be equipped with a number of good quality flashlights and spare sets of charged batteries. These are not only useful for moving about and trimming sails at night but also to aid in finding people that have fallen overboard. For this reason at least 2 of the lights should be of the lantern type or an equivalent.

3.8. Safety Flares

Refer to the appropriate government regulation for your size of yacht.

3.9. Fog Signals and Radar Reflectors

Both of these items are extremely important when sailing conditions deteriorate and visibility is severely restricted.

Foghorns of the canister type are good but a lung power model should also be available just in case. Sailboats are not easily picked up by radar so a radar reflector is a must especially at night and during bad weather. The radar reflector should be bought commercially and care taken not to damage it during storage or deployment as the accuracy of the reflector angles is very important.

CS30 Owner's Manual

4. Controls

This section gives a general overview of the location and operation of the controls for most of the amenities aboard the yacht. For details on the operation of any electrical, electronic or mechanical components installed by CS Yachts, see the appropriate manufacturer's manual.

4.1. Lighting

Each of the cabin lights has an individual switch located on the fixture itself. These are connected through a single breaker on the main panel. The running, fore, and steaming lights are all controlled directly through the main panel. All auxiliary electrical and/or electronic equipment must be wired through the main panel and space has been left to do so.

4.2. A/C Power

Your yacht is equipped with the necessary equipment to allow you to use 110 VAC 30-amp shore power onboard. Three double outlets are fitted in the forward cabin, galley and saloon. There is also a 10-amp battery charger, located in the port cockpit locker, which charges the battery when connected to shore power. A hot water system is also available for use with this system. The heater breaker should be turned off when tank is not full of water to prevent damage to the heater.

Note: The shore power should be disconnected while working on or near the main panel.

4.3. Battery

A 112 Amp 12 VDC battery is fitted to starboard of the engine while the state meter and primary control are to be found on the main panel. A second battery and splitter as well as a 20-amp battery charger are available as options and are recommended if the optional refrigeration system is fitted.

4.4. Galley

The galley is fitted with a stainless steel propane stove and oven. The propane tank is stowed separately and gas flow is controlled from the stove via a solenoid valve. The breaker for this valve is also on the main panel.

Note: For safety reasons the propane supply should be shut off at the tank when it is not in use.

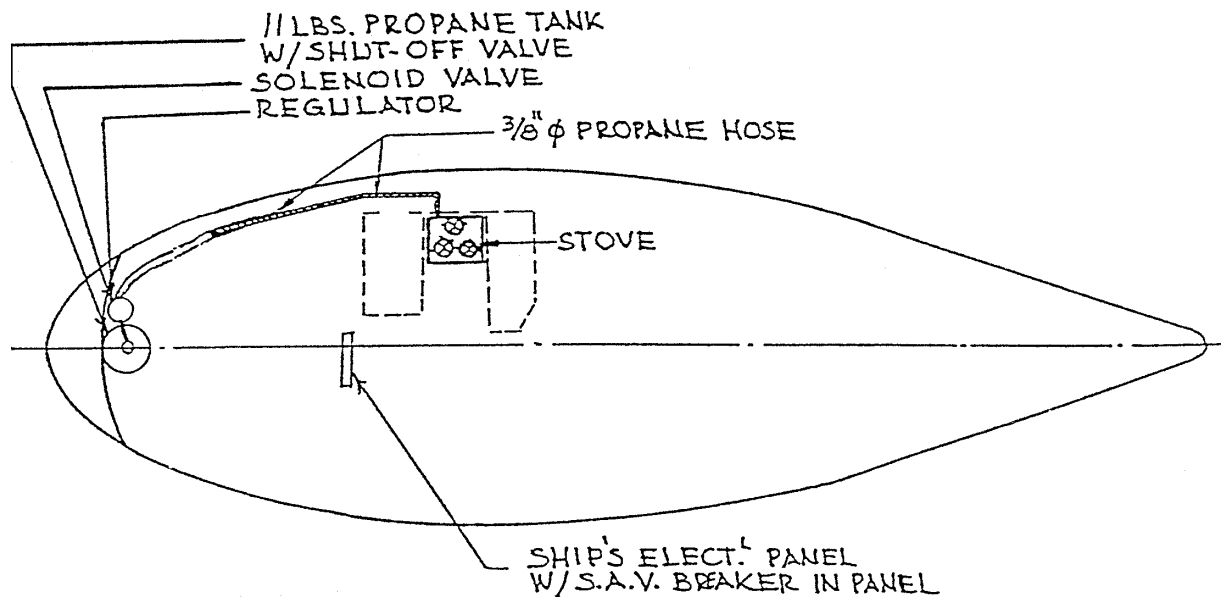

Figure 1 - Propane System with Solenoid Actuated Valve

4.5. Engine

The CS 30 is fitted with a single lever control mounted on the steering pedestal. The advantage of this system is two-fold. First of all it allows you to keep a hand on the helm at all times especially when maneuvering in tight quarters. Secondly, it is impossible to shift from forward to reverse at anything above an idle speed.

The red button on the side of the lever disengages the gearshift and allows it to be used solely as a throttle. The gearshift automatically re-engages when the lever is returned to the vertical position.

The Volvo instrument panel has provision for a tachometer, which is a factory-installed option. Oil pressure, temperature, and charge are also indicated on the panel. The panel also contains the compass dimmer switch, ignition switch, and engine kill switch.

Note: The engine is fitted with an anti-siphon valve in the cooling water circuit, which is vented on the port side just under the toe rail. When the engine is operated at high RPM, it's normal for cooling water to drain from this vent.

5. Launching Procedure

Important: Using a forklift to lift your yacht while it is stored in its shipping cradle is not recommended. A forklift tends to concentrate the loading on a small area of the hull, which may result in hull damage. If the boat is to be lifted in such a manner, the cradle should be reinforced and the forks placed under the fore and aft vertical supports.

5.1. Pre-launch Checklist

1. All through-hull fittings should be checked to verify that they are secure and that the valves open and close freely. At this time it is also advisable to close all through-hull fittings.
2. The batteries should be checked to ensure that they are fully charged and the terminals are clean. All electrical connections must be clean and securely attached.
3. Close all drain valves on the engine cooling circuit and prime the water pump by filling it with fresh water.
4. Clean and inspect the propeller and propeller shaft for excessive wear and/or damage. The strut bearing should also be checked for wear, which is exhibited in the form of excessive shaft play. At this time the propeller alignment should be checked according to the methods set down in section 10.5. If you have a folding propeller check that the blades open and close readily and, regardless of which type of propeller you have, check to insure that all the cotter pins are in place.
5. Wash the exterior of the hull and inspect it for any scratches or damage that may require attention.
6. Wax the hull to help protect the Gelcoat. You may want to add some pigment to the wax as this will help cover up small scratches and defects.

5.2. In-water Checklist

1. Check the stuffing box, the seal between the propeller shaft and the hull, for leaks. Small leaks, which are due to the seals drying out over winter, will disappear after the engine has been run for a short time. Propeller shaft alignment should be checked at this time according to the procedure set down in section 10.3. Note: Later boats use the Last Drop sealing gland that only requires inspection since it can not be adjusted.
2. All through hull fittings, sea cocks and the bilge should be checked for signs of leakage.

CS30 Owner's Manual

3. Open the raw water intake valve, which is fitted to the engine cooling water intake through-hull.
4. Check the fuel and all levels and top up as necessary.
5. Now start the engine and bring it up to operating temperature, while checking for signs of leaks. Once up to temperature turn off the engine and check the all level once again.
6. Add water to the waste system and flush it through thoroughly. Once this is done, pump out the holding tank and add a chemical deodorant to the system.

5.3. Stepping the Mast

Caution: Make sure that there is no risk of any part of the rigging or crane coming in contact with any sort of overhead lines as this could result in serious injury to the people involved and to the mast. Good maintenance and preparation of the spars (mast, boom, etc.) and rigging will pave the way to a trouble free season of sailing.

1. Lay the mast on 6 evenly spaced supports and wash it from top to bottom. At this time you should inspect it for any obvious areas of wear or damage.
2. Check all masthead sheaves and halyards for signs of excessive wear or damage. Note: When checking wire rigging for damaged or broken strands you should wear heavy gloves to prevent injury to your hands.
3. If the optional rod rigging is installed, it should be carefully inspected for cracks, nicks and dents as well as for cracked terminals. Cotter pins should be inspected to ensure that they are securely fastened and taped or covered so that they can not damage the sails. All damaged or worn pieces should be replaced and if you are in doubt or problems arise contact your dealer or the factory.
4. Inspect your spreaders for any sign of cracking or fatigue and test the mast lights so that bulbs can be changed before the mast is stepped. Turnbuckles should be checked, to see that they turn freely, and the threads lightly greased. If there are any adjustment marks on the threads, make sure that you do not alter or remove them as they will help you tune the rig.
5. Tie all running rigging together and secure the bundle to the goose neck to keep it out of the way. Similarly, the standing rigging should be bundled taking care to keep the lines in proper order so that they are not twisted when it comes time to attach them.

Note: At this point it is advisable to go back and double-check the above procedures.

CS30 Owner's Manual

6. Prepare a rope sling, strong enough to support the mast, and locate it approximately one foot above the mast light. It should be installed underneath all of the rigging to prevent it from damaging the mast or the rigging. A 1/2 in. line is to be attached from the sling to the goose neck to prevent it from slipping up the mast in such a manner that it does not interfere with any of the standing rigging.

Note: Ensure that the weight of the mast is carried solely by the sling and tie down to prevent damage to the mast light, spreaders, etc.

7. A minimum of 3 people, excluding the crane operator, should be present: 1) a person at the foot of the mast to support it as it is lifted vertical; 2) someone to keep the genoa-furling drum and mast clear of the crane's boom by keeping the base of the mast pointed towards the crane at all times; and 3) a person in the boat to guide the mast as it is being lowered to keep it from damaging the interior.

Note: Never position a person directly under the suspended mast.

8. When the crane is in position, the base of the mast should be passed up to a person on the deck and then the mast raised to an almost vertical position, ensuring that the mast stays clear of the crane at all times. The mast is now ready to be lowered through the deck, while ensuring that all electrical wires precede it through the hole. A board or piece of carpet should be placed between the bulkhead and the lower part of the mast to prevent the mast from damaging the teak as it is lowered. The standing rigging should be untied from the mast and attached when the mast is resting on its step. Initially only the stays and the upper shrouds should be attached and snubbed up by hand. Now the crane cable should be disengaged by lowering it, taking care not to damage the mast. It may be necessary to send someone aloft to retrieve the sling once the mast is completely secured.
9. Now attach the intermediate and lower shrouds and snug them up by hand also. The running rigging should be unfastened and run appropriately. The rig should now be tuned to obtain maximum performance, section 9.3 can be used as a guide for this. All cotter pins should be installed with the head facing forward or outward and then taped to ensure that they do not damage the sails.
10. The antennae and electrical wiring should now be reattached and tested to ensure that all of the components are functioning properly.

6. Winter Lay-up and Storage

This section deals with the work that must be done before you store your boat for the winter. Failure to perform these tasks could result in serious damage to the boat.

6.1. *Un-stepping the Mast*

Before removing the mast for winter storage, make diagrams of the electrical connections and of how you have the running rigging set up, as this will help in the spring when you are re-rigging the boat. In addition to this, mark the position of the turnbuckles on the screws with nail polish or black electrical tape as this will also help in re-tuning the rig in the spring.

- a) Remove the boom and associated equipment.
- b) Disconnect all wiring at the base of the mast.
- c) Remove the hose clamp from the mast boot.
- d) Masthead instruments should be removed prior to dismasting. (i.e., Windex, wind machine, etc.)
- e) Slings the Mast:
 - 1) Under the upper spreaders if there is enough height on the crane, this will be bottom heavy.
 - 2) Below lower spreaders, with great care, this will be top heavy.
 - 3) The ideal position is approximately 1 foot above the mast light, but be careful when moving sling up the mast.
- f) Undo all shrouds and halyards and tie them to the mast (do not let them hang freely as they can get caught in fittings, etc.).
- g) Station a person below at the mast step, to guide the mast out and prevent it from damaging the interior, and a person on the deck. A board or piece of carpet should once again be placed between the foot of the mast and the bulkhead to help in preventing damage. If you have a roller furling system another person is required to hang on to it. The mast once removed has to be prepared for storage by:
 - h) Pull all the halyards to masthead and then, coil, bag and strap them to the mast.
 - i) Shrouds can be removed, coiled and stored making sure all cups and swages are accounted for.

CS30 Owner's Manual

- j) J) Remove the spreaders and end caps to prevent them from being damaged.
- k) Seal masthead with plastic to prevent birds from nesting. Preferably the spar should be stored in sheltered enclosure. If you must store the spar outside, polyethylene sheeting may be used to protect it. Do not expose any spars wrapped in plastic to direct sunlight, and cut a few drain holes in the bottom of the sleeve so that any water formed by condensation will drain out.
- l) If the plastic covered mast is exposed to sunlight and moisture allowed to collect, discoloration of the spar may occur. Note: Do not use masking or filament tape on the spars.
- m) Coil and bag all of the boom's internal lines.
- n) Be sure that mast deck opening is well sealed using a cover and the hose clamp removed in d).
- o) All blocks, boom vang, etc., should be removed and stored at home or locked in the cockpit locker.

6.2. Hauling-out and Sling Location

The proper placement of slings and supports is most important when hauling out your yacht. Improper placement produces excessive stress levels in the hull and may result in Gelcoat fractures or other damage. The sling should never be placed on a propeller shaft or strut. The forward sling should be placed in the area of the forward main bulkhead, making sure that it is not covering any through hull fittings, and the aft sling in the area of the main companionway. Damage to the gel coat can be prevented by placing pads or old towels between the hull and sling. Tie a line between the 2 slings to prevent them from slipping apart.

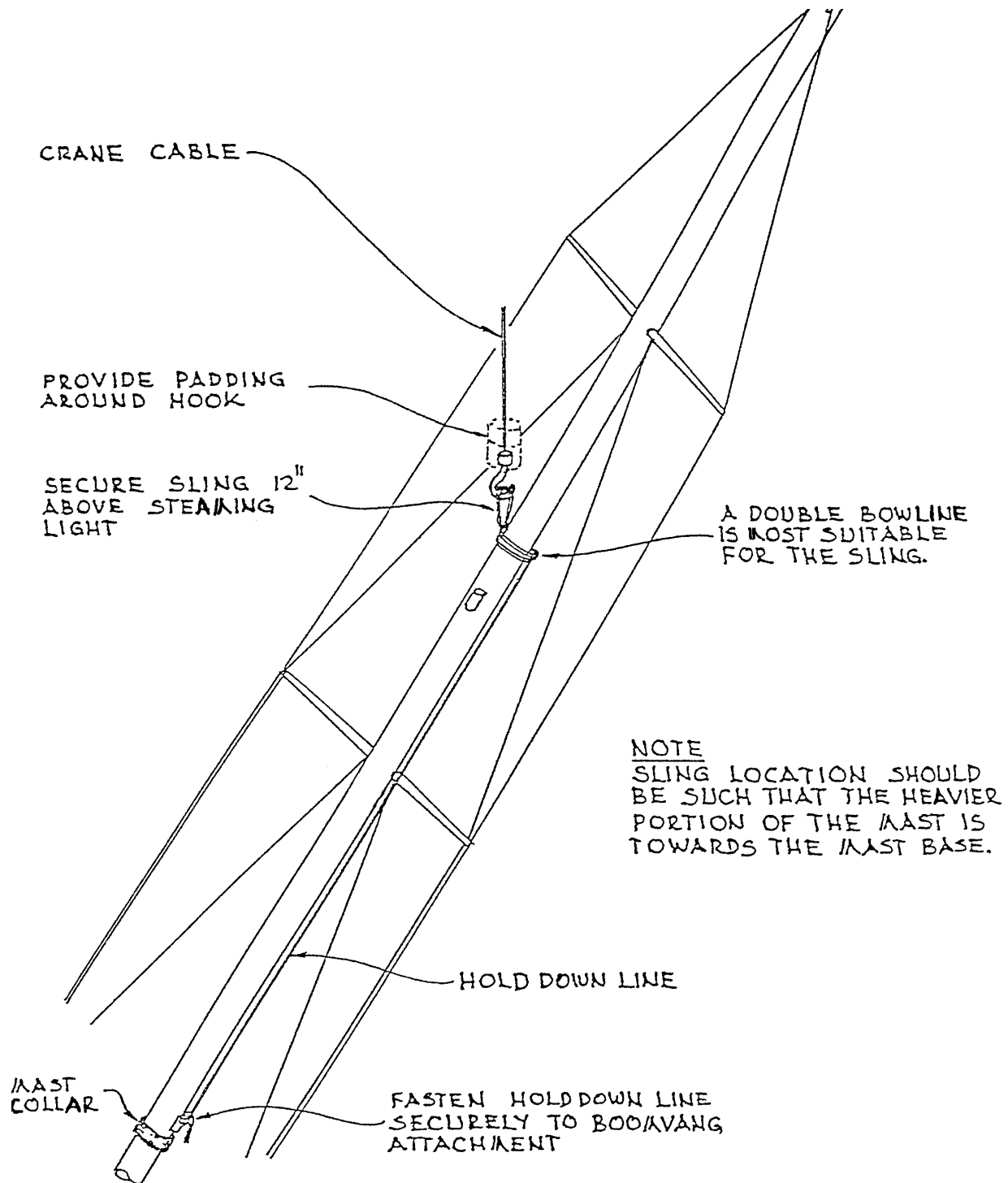

Figure 2 - Mast Sling Location

6.3. Cradle Support

When hauling out on a marine railway or placing the yacht in its winter cradle, a minimum of 60% of the weight of the yacht should be supported by the keel, while the

CS30 Owner's Manual

pads supporting the bottom of the hull should not bear more than 30 to 40% of the total weight. Structural damage may result if these weight percentages are not followed.

Do not put weight on the keel further aft than the last keel bolt as the extreme aft tip or the keel is relatively thin and will bend easily. It may be necessary to repeat the loading procedure a number of times, checking the keel position relative to the centerline of the cradle before final positioning.

It is important that the hull sits on a level plane, so that any water accumulating on the deck and in the cockpit will drain through the overboard drains. Therefore, ensure that the cradle is placed on level ground or shim it until it is level, while making sure that the cockpit drains are open.

All valves on through hull fittings below the waterline, such as the sink drain, should also be left open so that no water is trapped in the drain lines. Freezing water can rupture hoses and damage valves.

CS Yachts does not recommend that the yacht be stored with the mast left in place as this places stresses on the hull and rig not encountered during normal operation. Any damage to the yacht, its cradle or any associated part will not be covered under warranty if the boat has been stored with the rig in place.

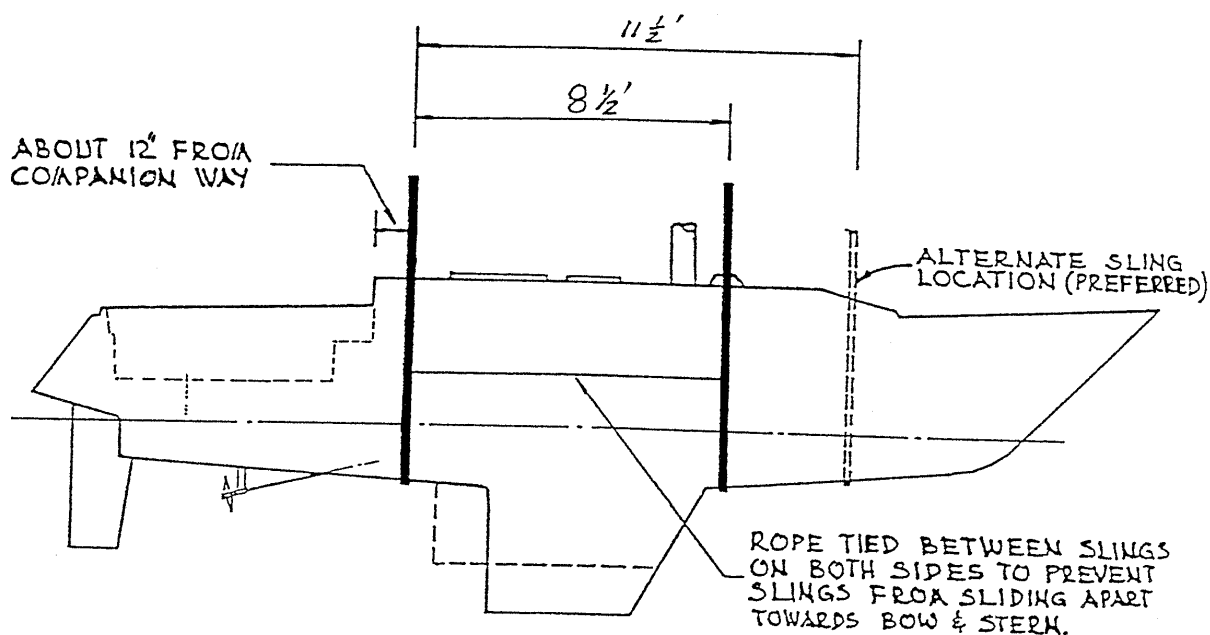

Figure 3 - Haulout Sling Location

CS30 Owner's Manual

6.4. Winterizing Procedure

- a) Scrub down the hull, to remove any dirt or marine growth, and wash down the deck and topsides.
- b) All the gear that may be damaged by cold and/or dampness, such as clothing, life Jackets, books, etc., should be removed and placed in a warm, dry storage area.
- a) Note: Be sure that all the sails, boom cover, sail sock, etc are dry before folding them and storing at home. During the winter the calls should be taken out and refolded, making sure to avoid the previous creases.
- b) Lubricate and/or cover all exposed mechanical fittings to guard them against the ice and the snow.
- c) Oil all the unvarnished woodwork to prevent it from drying out during the winter.
- d) Remove screens from the opening ports and replace them with the gaskets supplied.
- e) Remove all of the transducers and replace them with the appropriate plugs where applicable. This should be done before haul out especially in the case of the knot meter.
- f) Check all the mechanical and electrical components so that the ones needing repair or replacement can be looked into over the winter. You may, if you wish, remove all of your electronic instruments and store them at home over the winter.
- g) The engine should be winterized according to the procedure set down in the Volvo Engine Manual, but we have included a brief overview of what has to be done:

Remove the raw water inlet hose from the seacock and place it in a bucket of 50-50 ethylene glycol based antifreeze. Start the engine and run it until antifreeze comes out of the exhaust. Stop the engine and fit the hose back on the seacock. Now antifreeze is throughout the cooling system and the muffler. Remove the water pump impeller, clean it and lubricate it with a teflon based grease. The impeller should now be stored for the winter and not reinstalled until commissioning in the spring. An oil soaked rag or a wooden plug should be placed in the exhaust to prevent water from condensing in the system.

CS30 Owner's Manual

6.5. Head and Holding Tank

- a) Pump out the holding tank and flush it out with a deodorizing cleaner. The pump out access is located on the foredeck next to the chain locker. It is generally good practice to flush out your tank with fresh water each time it is pumped.
- b) Once the tank has been pumped dry add 2-4 quarts of ethylene glycol antifreeze to the toilet and pump it through the system and into the tank.
- c) The head should be prepared for winter according to the manufacturer's recommendations. This may entail removing some parts and storing them for the winter.

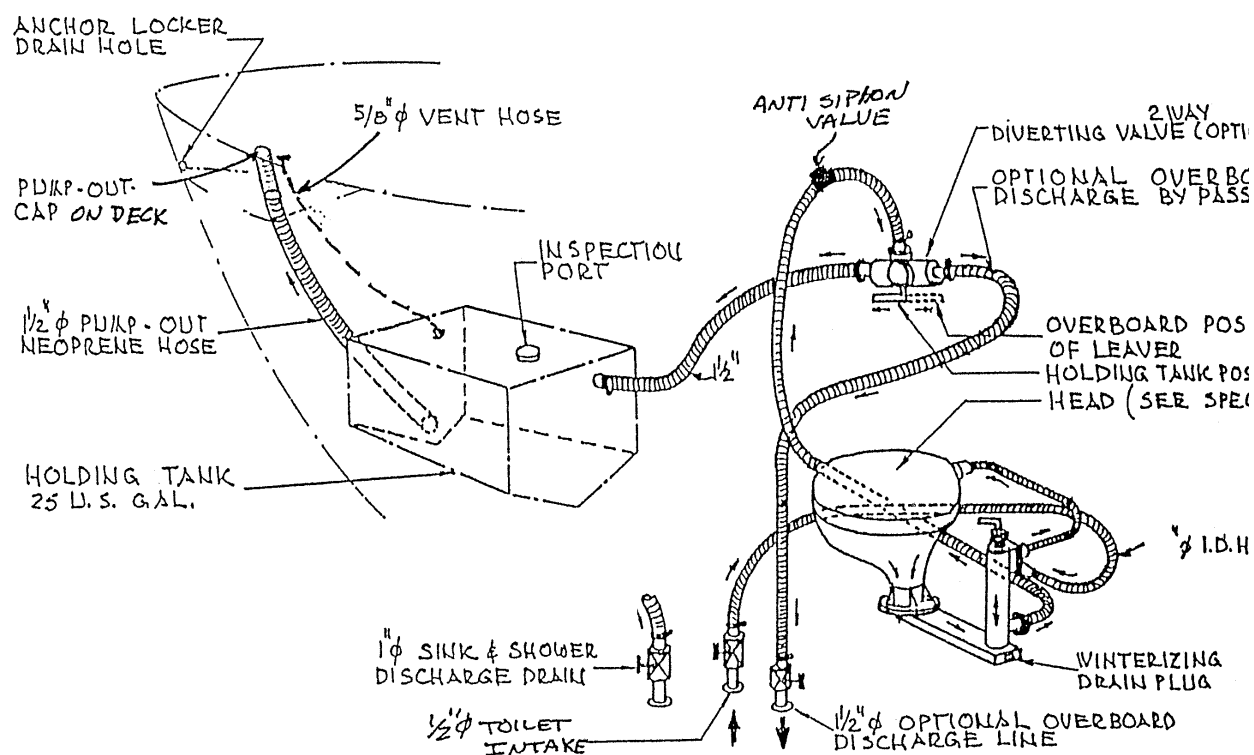

Figure 4 - Toilet Plumbing System

6.6. Fresh Water System

- a) For full instructions on the winterizing and maintenance of the water pump please refer to the manufacturer's instructions.
- b) The fresh water tank is located under the starboard settee and is accessed by removing the seat cushions and boards. The tanks should be winterized in the

CS30 Owner's Manual

following manner. The primary objective is to get all of the water out of the system so it can not freeze and cause damage. The tank must be pumped empty of water and a non-toxic antifreeze pumped through the system before the line connecting the tank to the pump is disconnected. Open all the faucets and disconnect all the lines at their lowest point so that the water can drain into the bilge. Uncouple the faucet supply lines, both hot and cold. If hot water is not fitted in your boat remove the faucet caps, to ensure that the faucets can drain completely. If your boat is equipped with a hot water heater disconnect the supply line and manually hold open the one way valve until the tank is drained.

- c) The pump should be run briefly to force any remaining water out but be careful as running the pump dry for more than a few seconds may damage it. .
- d) Leave all the faucets open once the system is shut down.
- e) Clean and dry the tank via the inspection port and once you are finished leave an open container of baking soda in it for the winter.
- f) When the entire system is drained, the bilge should be pumped dry and sponged clean. It is also a good idea to pour a small amount of antifreeze in to the bilge to prevent any water that may remain from freezing.

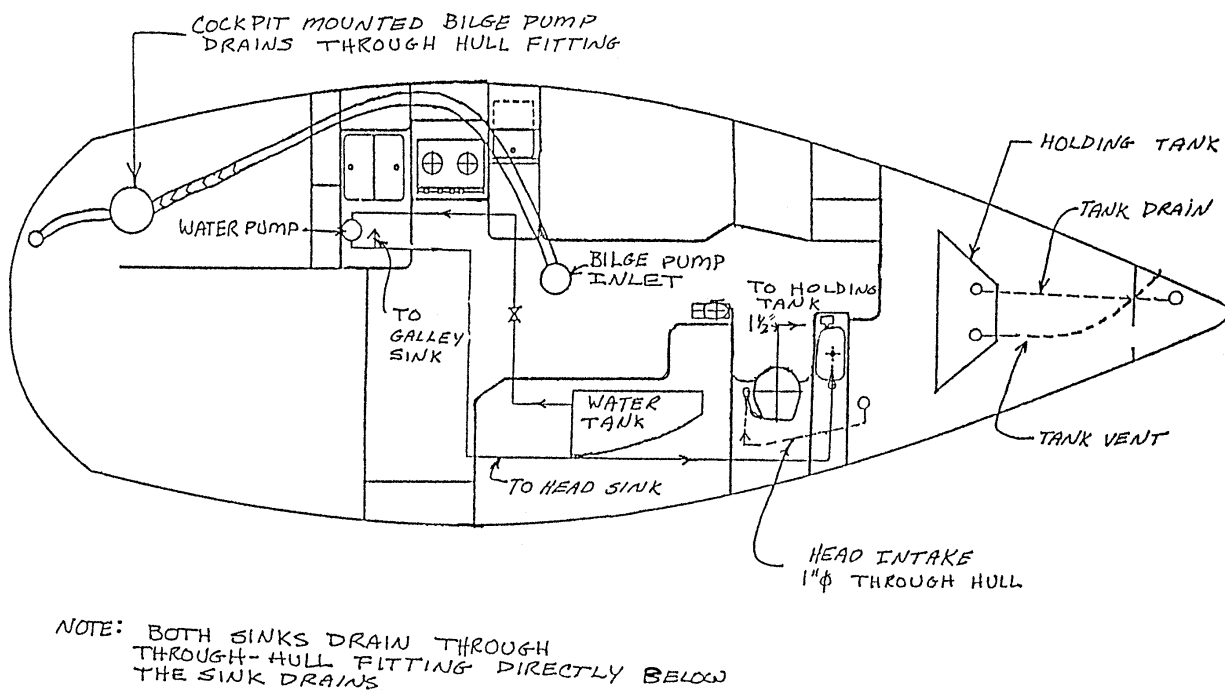

Figure 5 - General Plumbing Schematic

CS30 Owner's Manual

6.7. Auxiliary pumps

The discharge side of all pumps installed on board should be disconnected and the pumps drained. If this is not possible then an antifreeze/water mixture should be run through the pumps and lines to prevent them from freezing during the winter.

6.8. Ball Valves

All underwater through hull fittings are equipped with ball valves that should be flushed with fresh water and lightly greased during lay-up. It is considered good practice to close all the valves if the boat is to be left in the water unattended for a lengthy period of time, making sure that the engine water intake valve is reopened before starting.

6.9. Batteries

Remove the batteries from the yacht and store them, fully charged, in a cool protected place. Do not allow the batteries to freeze as this will damage their storage capabilities and may cause the casing to crack and leak acid.

6.10. Upholstery

It is best if the upholstered cushions are removed and stored inside for the winter. If this is not possible then stand them up on end so that there is as much air circulation as possible to minimize mildew.

6.11. Deck Hardware

Blocks and loose gear should be removed and stored in a dry place. Winches and other permanently fixed hardware should be lubricated according to the manufacturer's specifications and covered to protect it from the ice and snow. Sheets and running rigging should also be removed and stored in a dry place while lifelines should be labeled and put in bags for storage after removal. Fenders should be deflated and stored at home for the winter. If the shrouds are left attached to the mast then remove all the turnbuckles etc. and use a carpet to protect the mast from damage where the shrouds and stays are in contact.

If the boat is equipped with roller furling, ensure that it is securely tied to the mast. Do not let it sag!

6.12. Lockers and Enclosures

All lockers and enclosures inside the boat should be cleaned out and left open so that the air can circulate. The icebox should be thoroughly pumped and sponged dry with the lid left open.

7. Maintenance

To keep yachts in good and safe condition, maintenance on a regular and frequent basis is required. The frequency of such maintenance depends on the type and conditions of use. The running and standing rigging, engine, winches, lights, head, surface finish and bilge all need to be checked on a regular basis. If you are sailing in salt water, all deck hardware should be washed down after every sail and the hull washed down at least once a week.

7.1. Gelcoat Surfaces

All Gelcoat surfaces on the deck and hull should be cleaned with a non-abrasive cleanser on a regular basis to help maintain its finish. On the smooth surfaces a sponge or soft brush should be used while on the molded in non-skid surfaces a stiffer brush should be used. A thorough rinsing with fresh water should follow this.

At least once every season the topsides of the hull should be polished with a good quality boat wax to help the surface retain its color and finish. Dark colored hulls need more frequent polishing while the non-skid should not be waxed. The Gelcoat surfaces below deck only need to be cleaned with a mild detergent and should also be waxed occasionally.

In mooring locations with trees the decks should be scrubbed down more often as the leaves will stain the Gelcoat.

Minor scratches in the Gelcoat can be removed by buffing with a light abrasive cleaner or a fine rubbing compound and then followed by a good waxing and polishing. Scrapes or damage that have broken through the Gelcoat can be repaired with a Gelcoat repair kit, which is available from your CS dealer. For mayor damage, where large areas of Gelcoat are missing or if the damage has penetrated in to the glass lamination, you should consult your CS dealer and a qualified marine yard contracted to do the repairs.

7.2. Gelcoat Repairs

Gelcoat should be stored in a cool place, such as a refrigerator but do not allow it to freeze, to prolong its shelf life to from 6 months to about a year.

7.2.1. Application of Gelcoat

- a) Sand around the damaged area with #80 grit sand paper to key the surface for a good bond. After sanding clean the area with acetone so that no dirt or loose chips remain.
- b) Mask the area to be repaired so that the Gelcoat does not contact the surrounding areas.

CS30 Owner's Manual

- c) Use a Methyl Ethyl Ketone Peroxide 50% active oxidizing agent catalyst, which is available at most marine supply stores, for the Gelcoat. **Caution:** The catalyst is highly toxic, flammable and corrosive so it must be handled with extreme care. If you get it on your skin wash the affected area with plenty of water, immediately.
- d) Place the required amount of Gelcoat on a piece of cardboard or arborite and catalyze it at a rate of 5 drops of catalyst per tablespoon of Gelcoat. This will give it a gel time of about 1/2 hour at room temperature. During cooler weather a couple of extra drops per tablespoon can be added to maintain the same gel time. Be careful not to over catalyze as this will cause the Gelcoat to discolor; also, patching should not be attempted below 45° F.
- e) Work the Gelcoat in to the damaged area with a flexible spatula or putty knife. Leave the patch slightly higher than the surrounding area since it shrinks slightly as it cures and also this will leave material to sand.

7.2.2. Surface Finishing

- a) Allow the patch to cure from 2 to 4 hours, until the patch is hard, and then remove the masking and wet sand the Gelcoat. A Styrofoam block should be used to back up the paper starting with a #240 grit until the patch is flush with the surface and then follow up with #400 and #600 grit. If any flaws still exist patch them at this time.
- b) Once sanding is complete polish the area with rubbing compound until all the scratches are buffed out and the shine is restored.
- c) Apply a coat of wax to the entire area to protect the new surface.
- d) For major repair work, for example if the damage penetrates the hull, a competent marine repair service or the factory should be contacted.

7.3. Care of Hatches and Ports

All hatches and ports on the CS 30 are glazed Plexiglas, which is both impact and scratch resistant. The frames are made of cast aluminum with an anodized or epoxy coat finish.

To clean the hatches use a mild non-abrasive cleaner and a soft cloth. Do not use a gritty cleanser or dry wipe dirt as this may scratch the Plexiglas surface. Scratches that do occur may be removed polishing with progressively finer rubbing compounds or with an acrylic polish. These are both available at marine supply stores but toothpaste can be used as a substitute as long as you wash and rinse the ports after you are finished.

In salt water conditions the hatch windows should be washed both inside and out often. In time, after prolonged use and exposure, the neoprene seals on them may deteriorate and have to be replaced.

CS30 Owner's Manual

7.4. Teak

Teak on your CS 30 has been reduced to a minimum for maintenance reasons, hence only the companionway hatch and the optional cockpit table are solid teak. When exposed to the elements, teak will develop a dull gray appearance unless it is oiled frequently with marine teak oil. If the teak has lost its luster first wipe the surface clean of dirt and salt and then lightly sand the surface with #600 or #1000 grit sandpaper. After this, rub in several coats of teak oil using clean pieces of very fine sandpaper until the shine is restored.

The teak should be oiled 1 or 2 times a year. Any teak in the galley, which has grease or steam stains, should be cleaned with a mild detergent and then oiled in the manner described above.

7.5. Bottom of the Hull

The bottom of the hull should be painted with a good quality anti fouling paint, remembering that proper application is very important and that manufacturer's instructions should be followed at all times. The frequency of bottom maintenance depends entirely on the water in which the boat is operated (e.g., the amount of pollution and the rate of marine growth).

Upon haul out, and if the boat is to be dry docked for any period of time, the bottom should be scrubbed clean of all marine growth using brushes, detergent and plenty of fresh water. If a very smooth surface is desired then the anti fouling paint can be wet-sanded or rubbed with a piece of canvas. Also any bare spots should be touched up with the original type of paint.

There has a reported increase in the incidence of cosmetic blistering on yachts over a year old so it is recommended that 2 to 3 coats of a good waterproof epoxy paint be applied. The osmosis, or water absorption, problem is a persistent one that should be promptly looked after. As of yet, the Gelcoat manufacturers don't have an answer to this problem and it is not covered under our limited warranty.

7.6. Lifelines Pulpits and Stanchions

Maintenance of these is very important as a person's life may depend on it. The lifelines require the same periodic checking and maintenance as the standing rigging especially checking to see that the connector ends are fully screwed into the barrels and that all the lock nuts are tight. The pulpits and stanchions should be checked for damage and corrosion as well as ensuring that they are still securely fastened to the deck.

7.7. Winches and Blocks

Periodic maintenance of these items is a must as most of the problems associated with them are due to poor or inadequate maintenance. In a salty environment winches should be flushed with fresh water after use and chrome and stainless drums be kept polished. Aluminum drums need to be kept covered when not in use to stop the black

CS30 Owner's Manual

anodization from fading. Under heavy use the winches should be stripped for cleaning and lubrication once a month, especially in salt water, while once or twice a season is sufficient under normal use. The bolts securing the winch to the deck should also be checked a couple of times a season for safety's sake.

Blocks usually require little service but should be checked for damage or wear due to heavy use. An application of a silicon-based lubricant periodically will generally keep the blocks and sheaves running freely. The mast head sheaves should be checked when the mast is stepped and, depending on usage, a few more times during the season for wear or damage due to the halyards.

Note: Never leave a snatch block open while applying a load as this may bend the block's cheek.

7.8. Standing Rigging

Standing rigging includes all parts of the rigging that help to support the mast. The standing rigging should be examined prior to every sail with a detailed inspection at monthly intervals.

The turnbuckles should be checked for open cotter pins and the spreaders for alignment and to ensure that their pins are in place. Spreader ends should at all times be capped or taped such that the Genoa is not exposed to any sharp edges that may damage it. The wire rigging should be checked for broken or protruding strands and signs of wear or rust.

It is good practice, especially when sailing in salt water, to paint a small mark around the stays where they enter their terminals. This will provide an indication as to whether or not there has been any slippage and will prevent salt water from entering cracks in the wire and initiating corrosion.

7.9. Running Rigging

Running rigging encompasses all the gear that is used in handling the masts such as sheets, halyards, guys, boom vang, etc. The halyards may be rope or a rope wire combination. The wire halyards are subject to high loads as they pass over the sheaves at the masthead and so are subject to fatigue. These halyards, as well as the wire to rope splice, should be inspected for signs of wear and failure. The CS30 uses all rope halyards as standard equipment.

The rope halyards are less subject to wear and only need to be inspected a few times a year. Frayed lines should be replaced as and when needed.

7.10. Engine and Drivetrain

The engine and drive train should be maintained according to the specifications set down in the manufacturer's manual.

CS30 Owner's Manual

7.11. Electrical System Maintenance

The electrical system usually requires little or no maintenance. The exposed terminals and connections only need to be checked a few times a year to ensure that they are secure and free of corrosion. Applying a light coating of lubricant or grease can protect exposed terminals.

Note: if you are working on or near the main panel make sure to disconnect the shore power.

The batteries should be periodically checked with a hydrometer and distilled water added as needed. The battery fluid should be about 3/8 in. above the battery plates. The battery should be kept clean and the vent holes clear. Battery terminals must be kept tight and can be protected from corrosion by applying a thick coating of grease to the entire terminal.

To clean the battery, remove it to a place that will not be damaged by acid spillage. The vent caps should be checked to see that they are tight and then the entire battery scrubbed clean using a brush dipped in a solution of dilute ammonia or baking soda and water. Scrub until all the bubbling stops and then rinse the battery with fresh water.

7.12. Upholstery

The standard upholstery used by CS Yachts is made of nylon or a nylon/rayon mixture. These synthetic materials have been chosen because of their resistance to the mold and mildew found in marine environments.

Note: it is recommended that the customer have all the interior upholstery in his yacht Scotch Guarded since the material will discolor.

The upholstered cushions and seat backs are fitted over foam with zippers on the back to ease their removal. The covers must be dry cleaned and not machine washed if laundering is required. If the yacht is to be left unused for some time then it is advisable to stand the cushions up on end so that air can circulate around them. Also lockers should be cleaned out of any damp clothing and leave the doors open.

8. Construction

8.1. *Hull*

The hull of your CS 30 yacht is a hand made one piece molding constructed of the finest materials available. It is reinforced at areas of high stress and is made even stronger by placing a molded spine and girder module in the center of the hull. This module carries most of the load from the mast and the keel giving the boat exceptional integrity.

8.2. *Hull & Deck Connection*

The deck is fastened to the hull by bolting through the toe rail with stainless steel bolts at 4-inch centers. The soft butyl rubber gasket, which is used in the joint, is forced into all the crevices and gaps as the bolts are tightened forming a watertight seal. If a leak should develop the deck bolts can be tightened while making sure that the bolts are not turning.

8.3. *Deck*

The deck and cockpit are formed from a single GRP molding with an integral anti-skid surface on all the working areas. All the horizontal sections use the balsa core sandwich construction to provide extra strength and rigidity.

8.4. *Steering and Rudder*

Your yacht is equipped with a pedestal steering system and 36 inch destroyer style wheel. The system on the CS 30 is made by Whitlock Marine and employs a chain and wire system. This has the advantage of being a very strong and simple system that promises years of trouble free use and low maintenance.

The rudder is supported at three points along the stock. The bottom is supported in a bronze casting that is bolted to the skeg and fitted with a nylon bushing. Where the rudder stock passes through the hull, it is held in place with a packing gland which is through bolted to a mounting flange on the inside. The stock is further supported by a bearing that is bolted to the aft bulkhead.

The provision for emergency steering is made via an access hole on the center of the transom coaming. The emergency tiller, which is supplied, is lowered onto the rudder stock by removing the transom cap and aligning it with the slots inside the tube.

8.5. *Ballast*

There are three keels available for your yacht: deep, shoal, and wing. All of the keels are cast in a lead, antimony alloy for superior strength and dimensional accuracy. The keel is bolted to the hull with #316 stainless steel bolts. The bolts have an ultimate strength of 90,000 psi, which means that each bolt can hold approximately 7,000 lbs.

CS30 Owner's Manual

The bolts themselves are imbedded to various depths within the keel casting ensuring a large margin of safety during normal operation.

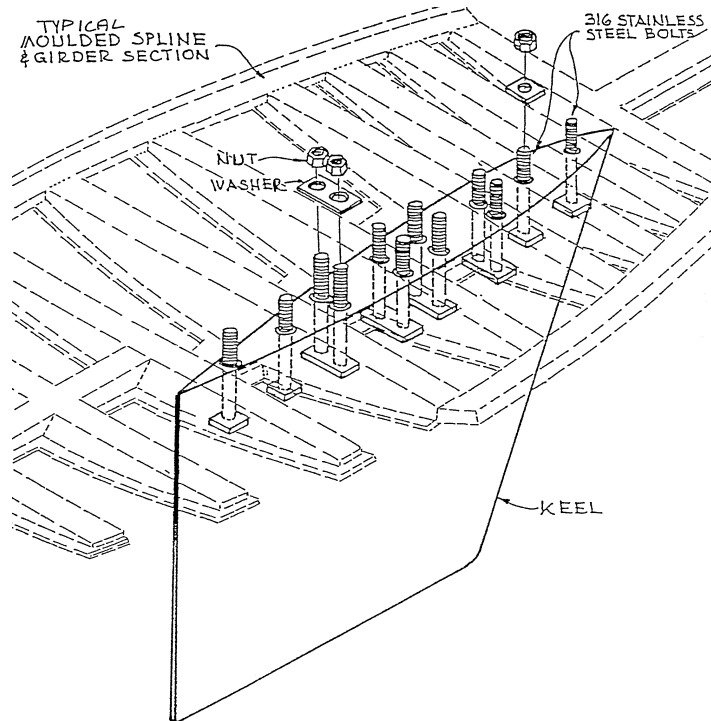

Figure 6 - Typical Keel Attachment

8.6. Interior Construction

[Note: This section has been added to the original manual with credit to CS30 Owner _____]

8.6.1. Removing the cabinets in a CS30 (Port Side)

I've discovered a couple of small rainwater leaks coming from small holes drilled through the hull/deck joint. I suppose these holes are left over from when it was assembled.

I found a small screw at the forward end of the shelf base that goes down into some of the molded GRP. It looks like the back end of that shelf is mounted on the molding for the galley counter. I just don't see any parts that can be unbolted and removed from the cabinets.

I have the locker and shelf removed now, allowing me to get to the two small holes in the hull/deck joint. There was a fair amount of water damage to the plywood paneling that is behind that shelf, but no damage to anything else. The plywood didn't look bad before removing it. There was a bit of a water stain at the forward top corner and some evident delamination at the rear top area. I was surprised to find that the inner layers are really coming apart. I'll probably just make sure it is well dried and glue the laminate back down as well as I can and put it back in. This is a purely cosmetic piece of wood and it doesn't look bad. Since it matches the other side, I won't replace it.

CS30 Owner's Manual

There are six screws that hold the shelf and cane-door locker assembly in place:

- ◆ 1 at the front end of the shelf, going down into the GRP molding
- ◆ 2 at the aft end of the shelf, inside the locker
- ◆ 2 inside the locker, going through the side into the dish cabinet
- ◆ 1 from the wood countertop rail (fiddle) going forward into the side of the locker (it is covered by a teak plug)

Once these six screws are removed, the shelf and locker lift out as a unit. I removed the settee backrest to make it easier to handle.

I am planning to clean up the inside of the two small holes by drilling them out with a slightly larger diameter drill bit, then wash with acetone. I will then put the tip of a caulking gun into the hole and inject as much 3M 101 Marine Sealant as it will hold, while somebody watches on the outside for escaping sealant. If the deck laminate where the hole comes through is clean, the sealant should adhere to it and keep the water out from the hull/deck joint area, keeping it between the toerail and the deck. Now I can get to all the bolts for the forward half of the toerail, so if it comes to that I can work it.

8.6.2. Removing the cabinets in a CS30 (Starboard Side)

I was able to get to the #4 stanchion on starboard by removing a panel the previous owner had cut inside the cane cupboard. If you have electronics flush mounted on the nav panel then you can access the bolts for the lifeline stanchion by removing any of the electronics from the cabinet above the nav desk and reaching through the hole in the paneling.

If there is much water in the bilge, like about 3 cups (750 ml for Canadians), and the boat is going to weather on a port tack, the water will slop up inside the storage compartment below the navigation desk and run forward onto the bottom of the starboard cushion through where the liner and the vertical header for the navigation desk join together. There is a nice little channel there to collect the water.

8.6.3. Opening Ports

BTW, we have all six opening ports removed so that we can clean and reseal them. I think this is the first time they have been taken out. After 12 years, they had developed small rainwater leaks.

9. Rigging

9.1. *General*

The CS 30 uses an extruded anodized aluminum mast made by Isomat, which is generally considered to be one of the best in the world. All halyards are internally housed and all electrical wiring is encased in a plastic conduit within the mast. A track line is left within the mast to further installation of halyards and wiring quicker and easier. A thorough inspection of all parts of the mast should be carried out before launching and after haulout every year.

The rig is classified as a double spreader and has a set of three shrouds or wire cables on each side of the boat. These shrouds, which are usually wire cable though rod rigging can be specially ordered, run to the chain plates on the deck and are positioned so as to maximize the lateral stiffness of the mast. Lines also run fore and aft and are used to adjust the shape of the mast as well as to support it. To achieve the best performance from your boat the rig must be tuned.

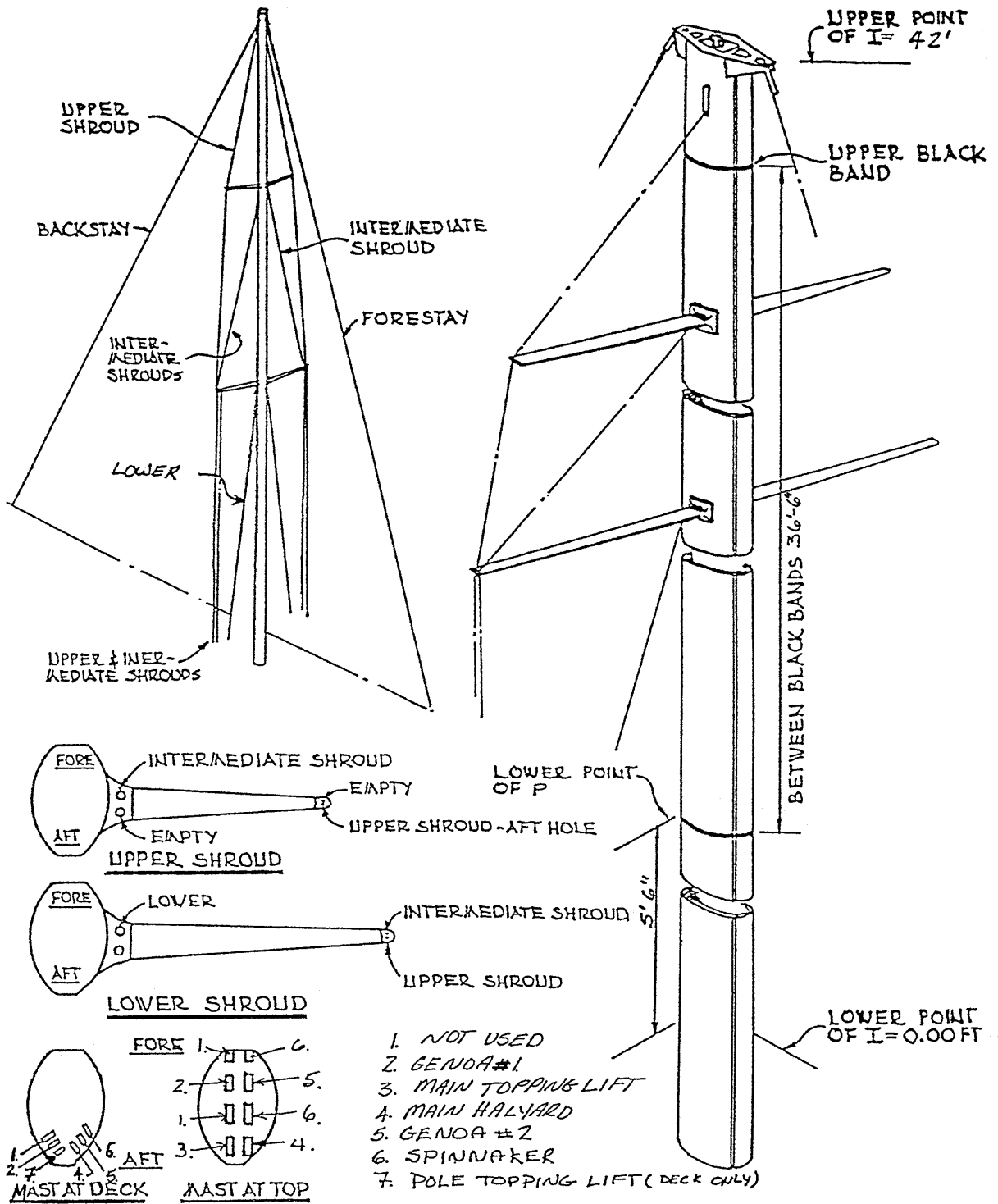

Figure 7 - Mast & Rigging Layout

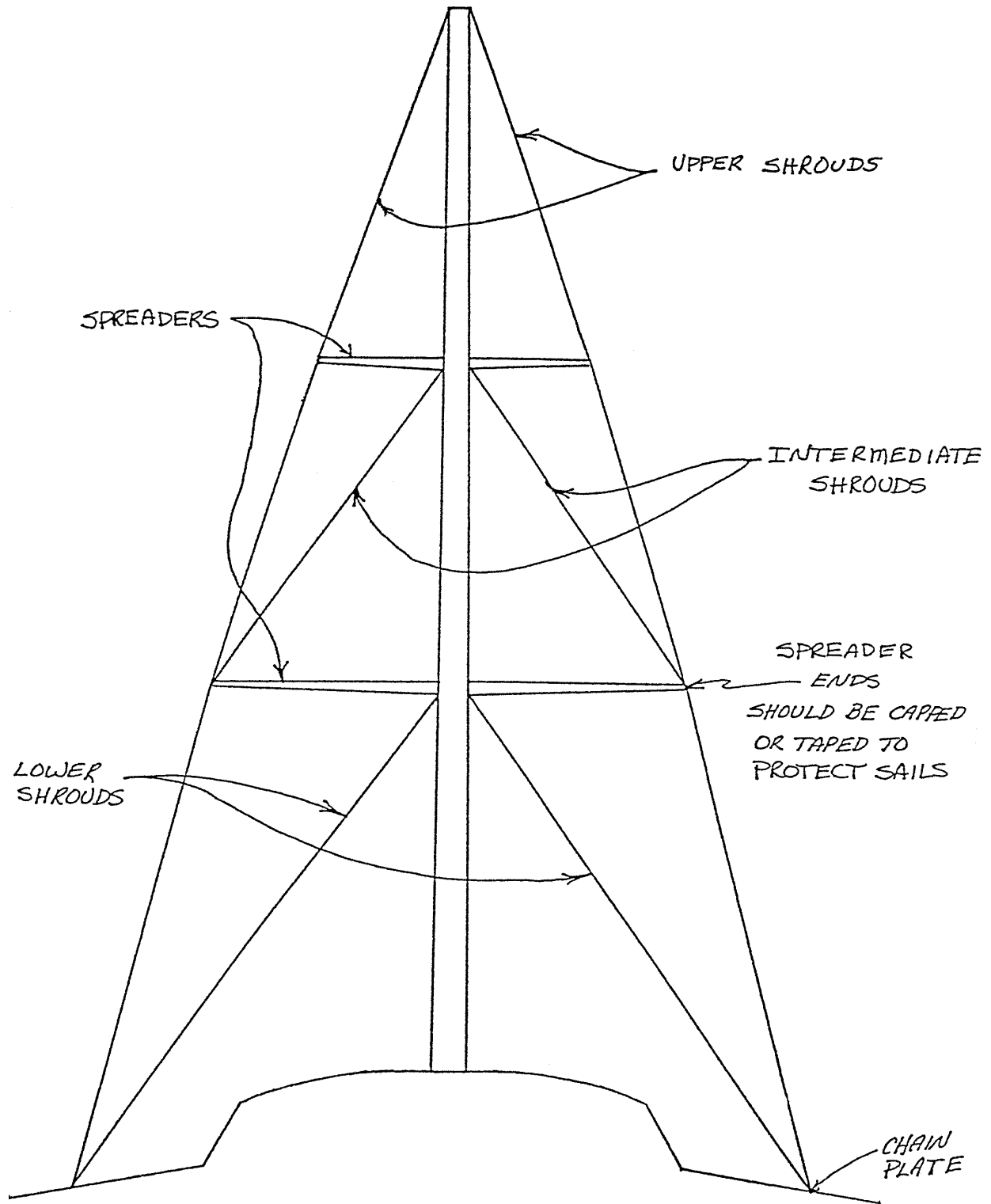

Figure 8 - Spreader Arrangement

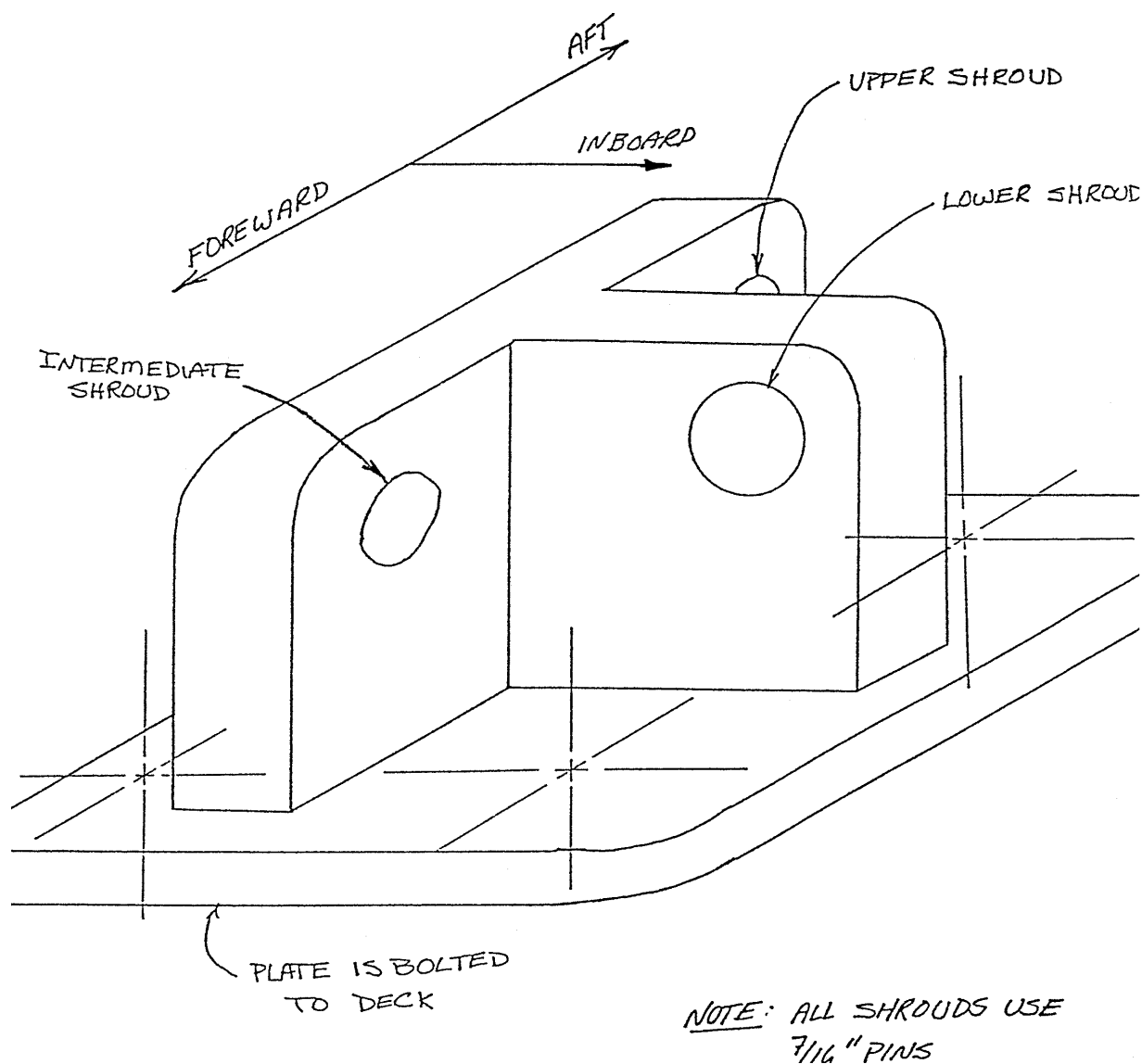

Figure 9 - Chainplate & Shroud Detail

9.2. Rig Tuning

Tuning involves adjusting the tension in the shrouds and stays to optimize the shape of the mast for most sailing conditions. The process involves 2 basic steps: a) Static Tuning and b) Dynamic Tuning.

Note: all the turnbuckles should be equipped with the factory specified toggles to prevent torsional loading of the stays and chain plates.

a) Static Tuning

The mast should be placed in the maststep with the wedges in place. For proper operation the mast must be centered and perpendicular to the transverse waterline of the boat. This is done by taking one of the halyards and cleating it so that the shackle

CS30 Owner's Manual

just touches the toe rail on one side of the boat aft of the mast. The upper shrouds are now snubbed up so that the halyard just touches the same point on the port and starboard rails. Once the mast is centered the shrouds are tightened starting with the lowers and working up making sure that the mast remains centered at all times. The tension on the shrouds will have to be rechecked when the boat is under sail.

The angle of the mast forward or aft is known as rake, forward rake is to be avoided at all costs. The top of the mast should be approximately 8 inches behind the bottom at the deck. This is checked by letting the main halyard hang down until it is just about touching the deck. At this point it should be 8 to 10 inches from the back of the mast. The rake is controlled by adjusting the fore and backstays in an appropriate manner.

b) Dynamic Tuning

The best day for tuning is one with steady winds of about 10 knots. Sailing close hauled, the leeward shrouds should remain tight at all times. Sighting up the luff groove the mast should be straight and if it is not, luff up and tighten the appropriate shrouds and recheck it. This should be repeated on both tacks until the mast remains straight at all times.

Your rig is now basically tuned but it is a good idea to check it after a few weeks when the rig has had a chance to settle. As you become more accustomed to your yacht you will probably want to fine tune your rig to maximize performance. This basically involves adjusting the amount of rake to influence the amount of weather helm among other things. Once the boat is completely tuned it is a good idea to mark the position of the all the turnbuckles to help in tuning the boat the next year.

CS30 Owner's Manual

10. Power plant and Transmission

10.1. Engine

The CS 30 is powered by a Volvo Penta 2002, 2 cylinder, 18 hp marine diesel engine. Details on maintenance and operation of this engine can be found in the manual supplied with the engine. These should be carefully read and understood before operating the engine. There is an exhaust blower, connected to the ignition switch, which vents the engine compartment when the engine is running.

10.2. Fuel System

An 18 gallon US aluminum alloy fuel tank is located in the port side cockpit locker. The fuel gauge is mounted on top of the tank and should be kept clear at all times and the fuel/water separator, which is located on the bulkhead Just forward of the tank, should be drained periodically. The fuel/water separator also removes particulate matter from the fuel preventing engine damage. The separator is drained by removing the plug on the bottom of the bowl and allowing the fluid to drain into a container. The CS30's built after #4449 should be fitted with a clear separator bowl.

To minimize condensation it is advisable to keep the tank filled up at all times with #2 diesel fuel. When fueling the boat the following procedure should be used:

- a) Extinguish all open flames, cigarettes and turn off the power at the main breaker.
- b) Touch the fuel nozzle to a metal deck plate to remove any static electricity before proceeding with fueling.
- c) After fueling close the cap tightly and wash down any fuel spills that may occur. it is also advisable to open all the hatches and run the blowers for about 5 minutes afterwards.

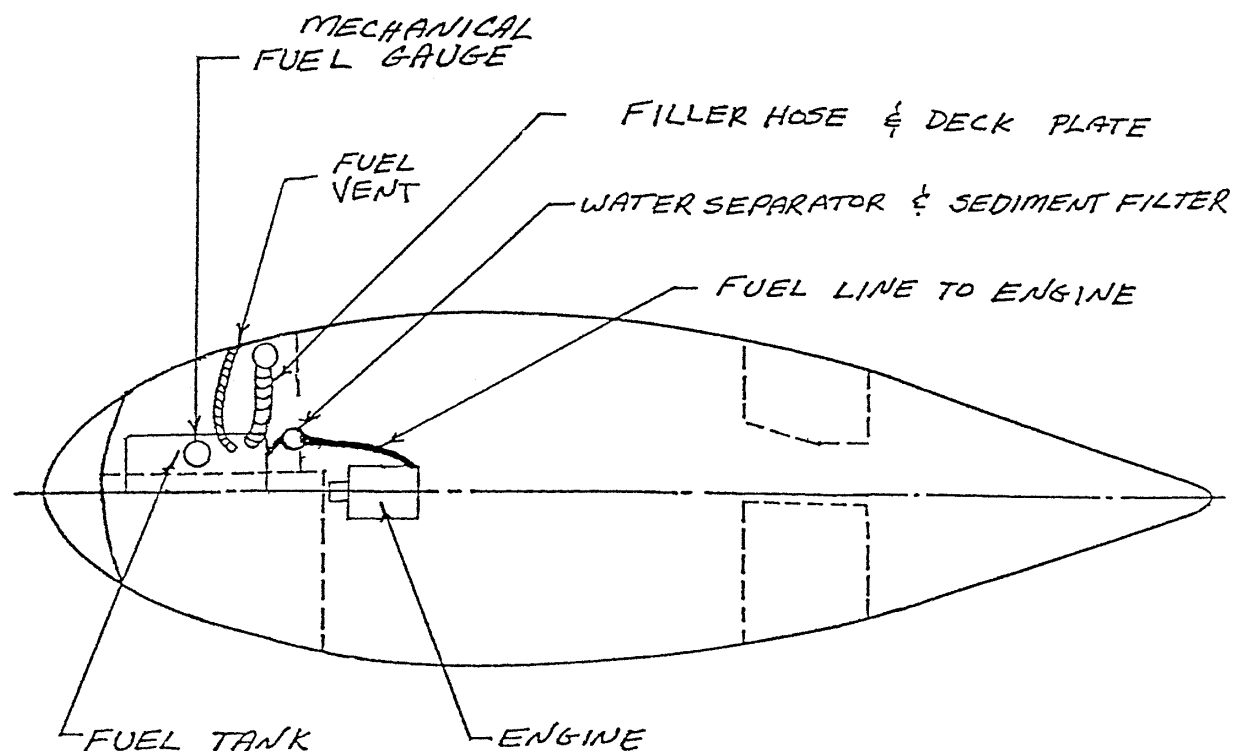

Figure 10 - Fuel Tank Installation

10.3. Propeller Shaft Alignment

The propeller shaft, which is a cathodically protected 1-in. diameter, #316 stainless steel shaft, is supported by the shaft coupling inboard and by the P-bracket outboard. The P-bracket contains an anti-friction cutlass bearing held in place with 2 set screws. The entire assembly should be checked for corrosion and wear every time the boat is put in or removed from the water.

The propeller shaft is carefully installed and aligned at the factory prior to delivery but should be rechecked every time the boat is launched. Alignment should also be checked if excessive vibration or loss of power is noticed during operation.

Check the alignment by first removing all the bolts in the shaft coupling and supporting the weight of the shaft by hand. The mating surfaces should be held together and a feeler gauge used to see if the coupling faces are aligned. If the feeler gauge does not pull evenly around the entire coupling then misalignment exists. This is corrected by adjusting the engine mounts and rechecking the alignment until the shaft is aligned. If this does not produce satisfactory results then a competent marine yard should be engaged to look into the matter.

CS30 Owner's Manual

10.4. Stuffing Box

A new stuffing box (Last Drop), introduced on boats built after May 1987, utilizes O-rings for a better seal. Details of this are included in the manufacturer's information, which is included with the boat.

The stuffing box is located at the inboard end of a fiberglass tube passing through the hull. A flexible rubber boot connects the fiberglass tube and the stuffing box. The entire assembly should be inspected on a regular basis. If there is only a slight leak no adjustment needs to be made. If the leak is excessive, then the packing glands can be tightened by loosening the locking nut and tightening the gland nut a quarter turn at a time until the leaking just stops.

Note: The rubber boot should be replaced every 2 years and the gland replaced when necessary. The gland nut should never be over tightened as the idea is for the packing to leak slightly during operation and not at all when the engine is not running.

If the gland continues to leak after several hours of operation it should be replaced. The packing is replaced by removing the Teflon-asbestos packing and winding three turns of 1/4 in. tallowed flax packing clockwise around the shaft. The gland nut should be replaced and tightened until the leaking just stops. Finally retighten the lock nut. If leaking persists then a bent or scored shaft may be the problem and should be dealt with accordingly.

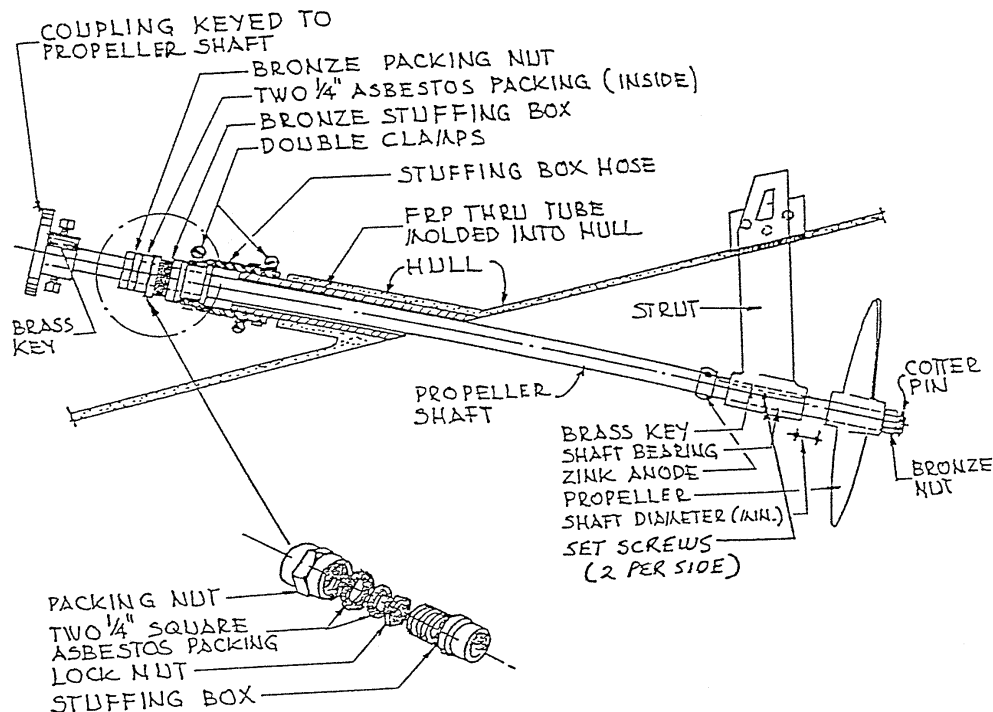

Figure 11 - Propeller Shaft & Stuffing Box

10.5. Propeller Alignment

Proper propeller alignment should be checked before launching in the spring and if there is an indication of damage during the year. Clamping a piece of metal or wood to the propeller shaft so that it just touches the edge of one of the blades does this. Now rotate the propeller by hand and if there is misalignment it will be indicated as the second blade moves next to the indicator. If the blade either hits or leaves a gap then misalignment is indicated.

If such a condition exists then the propeller should be checked and balanced by your dealer or a marine yard competent in such matters. If the propeller needs to be removed then a puller must be used so you don't damage the shaft or the propeller.

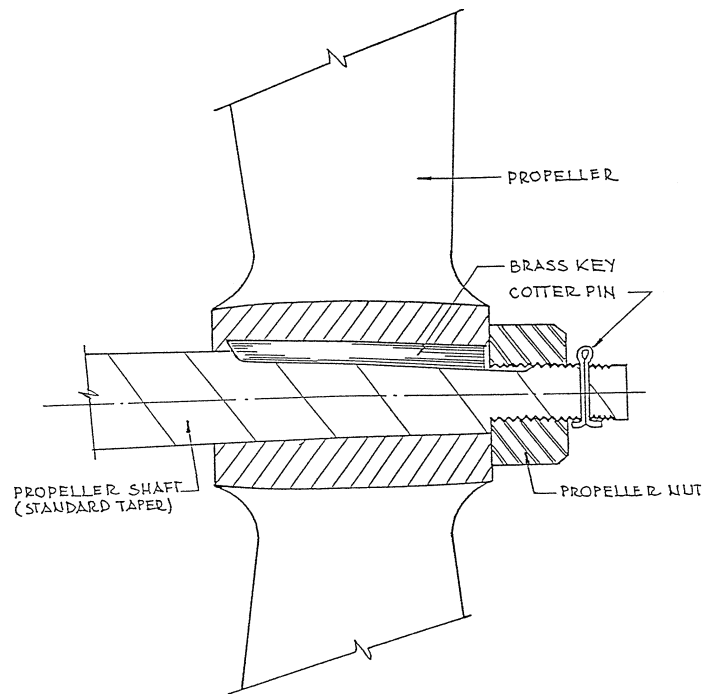

Figure 12 - Standard 2-Blade Propeller

11. Electrical

Your CS 30 is wired to use 12 VDC battery power and 110 VAC, 30 Amp shore power. Both of these are run through a breaker panel located behind stairs leading down from the cockpit. All the wiring is run as high as possible to reduce the risk of exposure to water. A conduit is bonded to the starboard side of the hull to carry the bulk of the wiring forward.

Note: The shore power should be disconnected before any work is done on the electrical system.

11.1. Batteries

There is a 12V 112 Amp hr battery installed as standard equipment with a second identical battery available as an option. The battery was located under the sink on hulls # 4401 to # 4449 and under the starboard settee on boats after # 4449. To remove the battery use a standard carrying strap of the type that connects to the lugs being careful to avoid acid spillage.

11.2. Alternator

Your yacht is equipped with an engine-driven 50-amp (14.2V) alternator that charges the battery(ies) when the engine is being run. If the 2-battery system is installed then both batteries charge at the same time regardless of how the master battery switch is set.

11.3. Electronic Equipment

Most owners add some electronic equipment to their boats which requires masthead or through hull fittings. Since most instrument problems can be traced to faulty or improper installation, this job should be left, in most cases, to qualified individuals.

Each piece of equipment should be separately fused as well as being connected to the spare breakers fitted to the main panel. High amperage equipment such as radios should be connected directly to the battery, making sure once again that all equipment is properly fused. In all cases, manufacturer's recommendations should be followed for best results.

CS30 Owner's Manual

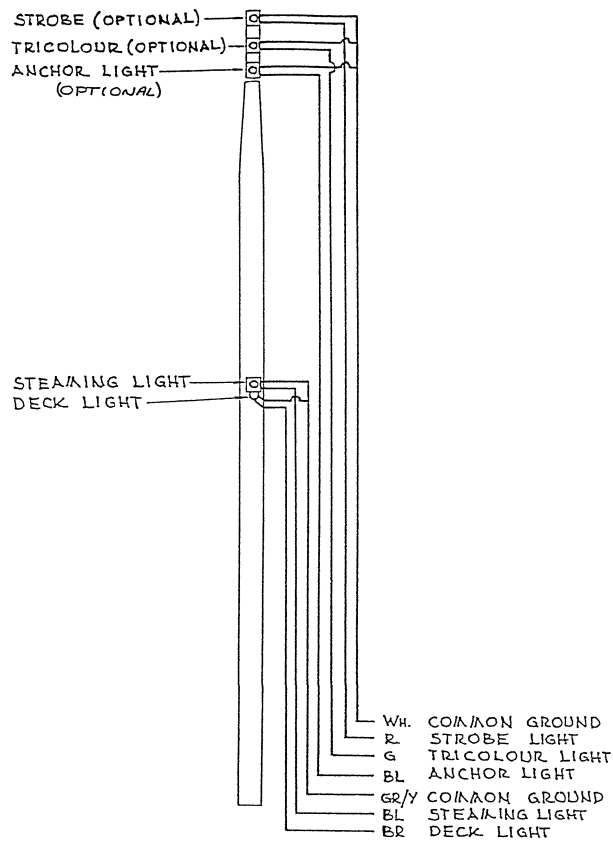

Figure 13 - Mast Lighting System

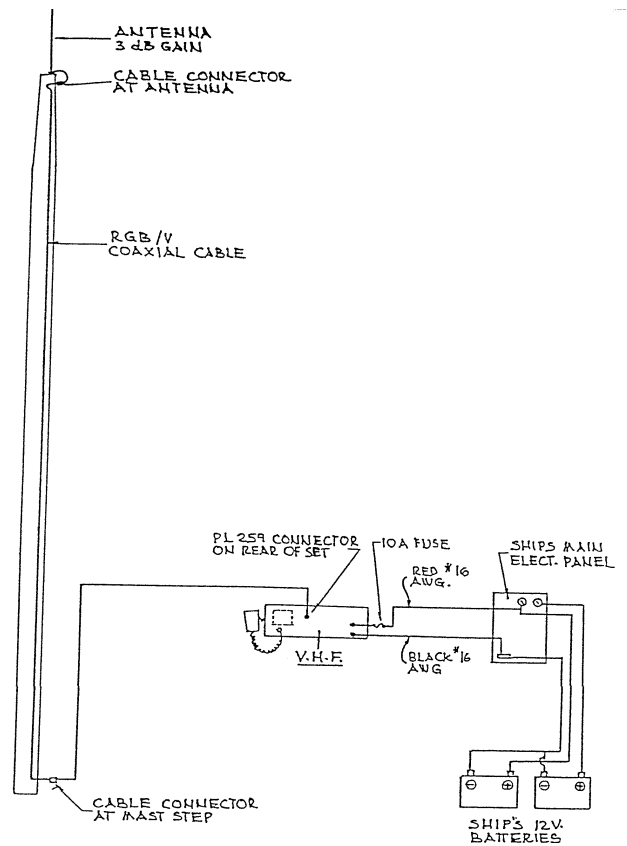

Figure 14 - VHF Radio Connections

12. Installation of Fittings

12.1. Deck Fittings

When locating deck fittings, make sure that reinforcement is available where you want to mount the equipment. Backing plates are not required if there is sufficient strength in the area but in all cases both plain and lock washers should be used. All the holes going through the deck should be sealed with silicone sealer to prevent leakage while the bolts should be checked-annually to ensure that they are still tight.

12.2. Through Hull Fittings

First consult with your local marine dealer or the factory for the proper through hull location. A GRP (fiberglass) backing plate should be used to support the fitting and all mating surfaces liberally coated with sealer to prevent leakage.

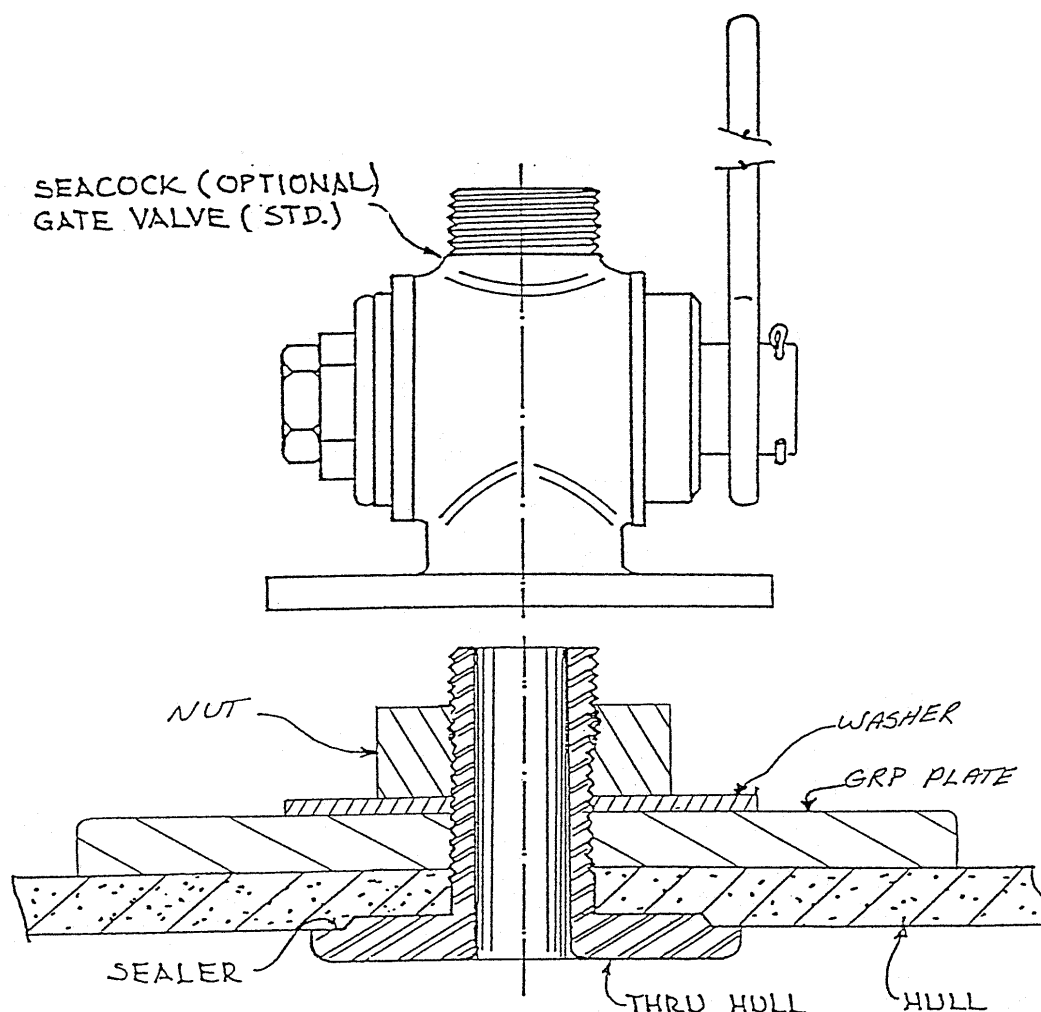

Figure 15 - Through Hull Fitting

CS30 Owner's Manual

13. Tables

13.1. Lubricants, Filters and Capacities

Engine	Volvo Penta 2002 - 18 HP
Engine Lubricating Oil	2.75L - SAE30 API/CD
Engine Oil Filter	Volvo Part Number 834337-8
Water Pump Impeller	Volvo Part Number 875583-7
Transmission	Volvo MS2 - straight drive
Transmission Oil	0.8L - SAE30 API/CD
Fuel	#2 Diesel
Fuel Tank	82L, 18 Imp. Gal., 21.6 US Gal.
Fuel Filter (Engine)	Volvo (Bosch) Part Number 829913-3
Fuel/Water Separator	Racor 220R - Filter Part Number R24
Fresh Water Tankage	113L, 25 Imp. Gal., 30 US Gal.
Holding Tank	113L, 25 Imp. Gal., 30 US Gal.

Table 4 - Lubricants, Filters and Capacities

CS30 Owner's Manual

13.2. Electrical Lights

Location	Pieces	Bulb Type
Bow Bi-colour	1	Ahelman & Schlatter 12V-25W, 2-pin offset bayonet 904-0002
Stern	1	Ahelman & Schlatter 12V-25W, 2-pin offset bayonet 904-0002
Masthead Tri-colour (optional)	1	Guest 12V-10W # P-13612
Masthead Anchor (optional)	1	Ahelman & Schlatter 12V-10W (discontinued)
Masthead Strobe (optional)	1	Quartz Halogen M-35, Guest replacement #P-17401
Steaming Light	1	Ahelman & Schlatter 12V-10W, festoon 904-00200
Deck Light	1	Aqua-Signal Halogen type OSRAM #64425 12v - 20W
Overhead Dome (white)	4	GE-1142 QL-7
Overhead Dome (red)	2	GE-94 SJ4
Bulkhead Lights	7	SL 94 2-pin bayonet
Chart Table Light	1	GE 1816 1-pin bayonet
Galley Fluorescent	1	F8 T5 CW
Cockpit Light	1	Windex Bulb type Osram #12v 3W
Compass Light	1	Dual 40,000 hr Bulb # A12925

Table 5 - Electrical Lights

13.3. Stainless Steel Components

Bow Pulpit	1" Diameter - 316 Stainless Steel
Stern Pushpit	1" Diameter - 316 Stainless Steel
Stanchion	1" Diameter x 25" - 316 Stainless Steel
Mast	48' 0" approx.
Mast Track Size	3/4" Flat Inset Slide, Holt Allen #90
Boom	12' 2"
Boom Bolt Rope Size	3/8"
Boom Tack Pin Cut Back & Height	1 1/2" & 2" - Clew slug provided fits 3/8"

Table 6 - Stainless Steel Components

CS30 Owner's Manual

13.4. Standing Rigging

ITEM	No.	Length Pin to Pin	Size & Material	Upper End Fitting	Lower End Fitting
Forestay	1	43' 8"	1/4" 1x19 SS	Isomat Terminal Cup	Merriman Turnbuckle #7854-101620 5/8" Pin
Backstay	1	47' 0"	1/4" 1x19 SS	Isomat Terminal Cup	Merriman Turnbuckle #7854-101620 5/8" Pin
<i>Backstay Breaking Strength = 8,200 lbs., Pre-load Limit (25-33% B.S. wire limit) = 2,700 lbs., Absolute Pre-load Limit (40% B.S. rod only limit) = 3,300 lbs.</i>					
Upper Shrouds	2	42' 5"	1/4" 1x19 SS	Isomat Terminal Cup	Merriman Turnbuckle #7854-101620 7/16" Pin
Intermediate Shrouds	2	29' 11"	1/4" 1x19 SS	Isomat Terminal Cup	Merriman Turnbuckle #7854-101620 7/16" Pin
Lower Shrouds	4	15' 5-1/2"	1/4" 1x19 SS	Isomat Terminal Cup	Merriman Turnbuckle #7854-101620 7/16" Pin
Upper Life Lines	2		1/4" 7x7 SS vinyl coated with turnbuckle		
Lower Life Lines	2		1/4" 7x7 SS vinyl coated with turnbuckle		
Jackstay	1	17' 8-1/2"	1/4" 1x19 SS	Isomat Stud	Merriman Turnbuckle #7854-101620 7/16" Pin

Table 7 - Standing Rigging Specifications

CS30 Owner's Manual

13.5. Standard Running Rigging

ITEM	No.	Layout	Material	End	End
Main Halyard	1	Wire 42'4", Ropetail 32'	3/16" 7x19 SS, 7/16" Dacron Braid, Yellow Fleck	Merriman 3900 Shackle	Whip
Genoa Halyard	1	Wire 42', Ropetail 33'	3/16" 7x19 SS, 7/16" Dacron Braid, Blue Fleck	Nicro Fico 11000S Shackle	Whip
Topping Lift	1	Rope 82'	5/16" Dacron Braid, White	Nicro Fico NF12000S Shackle	Whip
Main Sheet	1	Rope 58'	7/16" Dacron Braid, White	Soft Eye	Whip
Genoa Sheet	2	Rope 45'	1/2" Dacron Braid, White	Whip	Whip
Reef #1 Line	1	Rope 26'	3/8" Dacron Braid, White	Whip	Whip
Reef #2 Line	1	Rope 32'	3/8" Dacron Braid, Blue Fleck	Whip	Whip
Reef #1 Line led aft	1	Rope 40'	3/8" Dacron Braid, White	Whip	Whip
Reef #2 Line led aft	1	Rope 50'	3/8" Dacron Braid, Green Fleck	Whip	Whip
Vang Line	1	Rope 29'	7/16" Dacron Braid, White	Soft Eye	Whip
Spinnaker Halyard	1	Rope 95'	3/8" Dacron Braid, Red Fleck	Nicro Fico NF12000S Shackle	Whip
Spinnaker Sheet	2	Rope 65'	1/2" Dacron Braid, Red Fleck	Nicro Fico NF12000S Shackle	Whip
Spinnaker Guy	2	Rope 38'	3/8" Dacron Braid, Yellow Fleck	Nicro Fico NF12000S Shackle	Whip
Spinnaker Pole Lift	1	Rope 53'	3/8" Dacron, Red/Blue Fleck	Nicro Fico NF12000S Shackle	Whip

Table 8 - Running Rigging Specifications

CS30 Owner's Manual

13.6. Block Specifications

Usage	Description	Qty
Main Sheet	Lewmar 9217 Single	4
Main Sheet	Lewmar 9267 Fiddle Block w/Becket	1
Boom Vang	Lewmar 9258 Fiddle Block with Snap Shackle	1
Boom Vang	Lewmar 9288 Cam, Snap Shackle w/Becket	1
Reef Lines	Lewmar 9117 Single	2
Harken	Lewmar 9017 Single	4
Auto Reef	Lewmar 9117 Single	2
Auto Reef	Isomat Double Block	1
Spinnaker	Nicro Fico 10124B	2
Spinnaker	Lewmar 9118 Snap Shackle Single	1

Table 9 - Block Specifications